

# **Hamilton Manufacturing Corp.**

---

1026 Hamilton Dr. Holland, OH 43528 • Phone: 419-867-4858/800-837-5561 • Fax: 419-867-4857 • [www.hamiltonmfg.com](http://www.hamiltonmfg.com)

## **HTK Installation Manual**

# TABLE OF CONTENTS

<b>I. INTRODUCTION .....</b>	<b>4</b>
<b>II. INSTALLATION .....</b>	<b>5</b>
<b>MECHANICAL INSTALLATION .....</b>	<b>5</b>
Unpacking .....	5
Positioning .....	6
Mounting .....	6
Running Conduit .....	6
HTK Dimensions (For brick-in installation) .....	7
HTK Dimensions (Free Standing installation) .....	8
Brick-In Installation .....	9
Free-Standing Installation .....	10
Brick-In Installation .....	11
Free-Standing Installation .....	12
Gate Orientation .....	13
Access Control Lane Layout .....	14
<b>III. ELECTRICAL INSTALLATION .....</b>	<b>15</b>
Pulling Wires .....	15
Wire Terminations .....	15
Power Supply Wiring Connection .....	17
BRING MAIN POWER INTO OUTLET TO POWER MACHINE .....	17
Wash Interface .....	18
HTK “Automatic” Wiring .....	19
HTK “Gated Tunnel” Wiring .....	20
Additional Wire Terminations For Use With The Credit Card or Customer Value Card System. ..	21
Additional Wire Terminations For Use With A Hamilton Code System or POS 4000 .....	21
Additional Wire Terminations For Camera In HTK. ....	22
Setting Car Wash Cycle Synchronization .....	23
<b>IV. COMPONENT CONNECTIONS .....</b>	<b>24</b>
Power Supply .....	25
Controller .....	26
Smart Bus Hub .....	28
Bill Dispenser .....	29
Stacker Interface .....	30
Gate and Loop References .....	31

## ABOUT THIS MANUAL

PLEASE READ THIS MANUAL CAREFULLY PRIOR TO INSTALLING THIS UNIT. A complete understanding of the operation of this unit is essential for a successful installation. Refer to the Table of Contents for easy navigation through this manual.

This manual was designed to introduce the Hamilton Transaction Kiosk and to provide general information about installation. This manual will enable the installer to properly install the HTK and make the proper wire connections to the HTK. To obtain assistance from the manufacturer, please call (800) 837-5561 or (419) 867-4858. Or contact Hamilton Mfg. online @ <http://www.hamiltonmfg.com>.

When calling for assistance, it is important to have serial numbers readily available. Please record these numbers in the spaces provided.

HTK MODEL & SERIAL # \_\_\_\_\_

CONTROLLER MODEL & SERIAL # \_\_\_\_\_

HOPPER MODEL & SERIAL # \_\_\_\_\_

HOPPER MODEL & SERIAL # \_\_\_\_\_

STACKER MODEL & SERIAL # \_\_\_\_\_

VALIDATOR SERIAL # \_\_\_\_\_

BILL DISPENSER SERIAL # \_\_\_\_\_

LOCK/KEY # \_\_\_\_\_

Please complete the warranty card, which was included with your machine, and return it to the manufacturer.

# I. Introduction

---

---

This manual will describe the installation of the Hamilton Transaction Kisok from a mechanical and electrical perspective.

## **Automatic / Rollover**

- Brick in Mounting
- Schematic drawing of mounting configuration of HTK
- Schematic drawing of cabinet dimensions
- Schematic drawing of conduit mounting holes
- Schematic of HTK wiring connections

## **Tunnel / Gated**

- Schematic drawing of mounting configuration of HTK
- Schematic drawing of positioning of HTK and Gate
- Schematic drawing of cabinet dimensions
- Schematic drawing of conduit mounting holes
- Schematic drawing of wiring connections for HTK, Gates and Gated PLC

**NOTE: Website links to Gate and Loop information is provided on page 24.**

**\*IMPORTANT NOTICE: HAMILTON MFG. RECOMMENDS THAT THE HTK OPERATE ON A DEDICATED POWER SOURCE. UNDER NO CIRCUMSTANCE SHOULD ADDITIONAL EQUIPMENT BE OPERATING OFF THE DEDICATED POWER SOURCE FOR THE HTK.**

# II. Installation

---

---

**NOTE:** It is very important to read and understand all of these instructions before attempting installation. **Hamilton will not be responsible for injury due to improper installation.**

The installation process contains two distinct operations, **Mechanical Installation**, and **Electrical Installation**

## *MECHANICAL INSTALLATION*

### □ Unpacking

There are a number of points to keep in mind while unpacking your HTK. These items will make the installation and continued operation of your machine run smoother. These tips are listed below.

#### **Be sure to save your keys**

The keys and lock inserts are placed inside a cushioned envelope bag, then placed inside the machine located next to the power supply. When removing the shrink-wrap, be sure to locate the “T” handle crank and set it aside so it does not get thrown away. **MAKE A PERMANENT RECORD OF THE NUMBERS ON YOUR KEYS IN CASE A KEY IS LOST AND MUST BE REORDERED.**

#### **Remove the packing strap from the hoppers**

The hoppers comes shipped with a packing strap secured around it to minimize the vibrations caused by shipping. If this strap is not removed, the hopper will not tip out for easy filling. The strap may be cut off with a pair of wire cutters or sturdy scissors. Cardboard is placed around the edges of the hopper to protect it during shipping. After removing the strap, be sure to remove the cardboard as well. In addition to the removal of the card board and strapping, one of the hoppers will be holding the paper for the receipt printer.

#### **Remove all packing debris from the hopper**

During unpacking, ensure that debris does not fall into the hopper bowl. If this material is not removed, the hopper could jam. With the power completely disconnected, remove all loose material inside the hopper bowl.

#### **Remove HTK from shipping pallet**

The HTK is securely mounted to the pallet with 4 mounting bolts and nuts. To remove the HTK from the pallet, open the main door and locate the cushioned envelope to retrieve the key for the vault. Once you have the vault door open loosen and remove the two nuts from the bolts. Repeat this process on the two bolts on the side of the power supply. Once this process is complete, you will be able to remove the HTK from the pallet.

#### **Removal of additional packing materials**

Inside the HTK are additional components that have packing material holding the component in place for secure shipping. The following will need to be removed for proper operation. The first is the strapping around the Validator. Another is the removal of the tape around the coin mechanism. In addition the tape and paper on the front of the bill dispenser, this also includes the tape that holds the bill rejection tray. Finally the removal of the tape from the coin box, which need to be placed underneath the coin mechanism inside the cabinet.

## ❑ Positioning

There are no set guidelines for the placement of the HTK. However, it is recommended that the machine is positioned far enough away from the wash entrance to minimize the amount of overspray that may get into the HTK. Also, there is a typical height, from the pavement to the bottom of the cabinet, of **approximately 24"**.

## ❑ Mounting

It is recommended that the HTK be mounted in a permanent enclosure. Safety is a primary concern, so the equipment must be securely mounted. Hamilton recommends using one of the following methods:

### **Brick Mounted**

- The first method is to construct a brick or concrete enclosure that will house the HTK. Figure on page 7 (HTK Bolt Pattern Brick-In) gives the HTK mounting hole locations. The HTK provides for six 5/8" mounting holes. Have your engineer or contractor recommend construction suitable for strength and stability.

### **Base Mounted (Free Standing)**

- The other method involves mounting the HTK on an optional HTK Base . In this situation, the base is secured to the pavement and the HTK is secured to the base. Fasteners to be used should be recommended by your engineer as to strength and suitability.

**NOTE: The HTK that mounts to the HTK Base is specifically designed to be mounted together. Trying to mount a brick mount style HTK to the base, is not compatible.**

## ❑ Running Conduit

Typical electrical code requires low and high voltage wiring to be run in separate conduits. Because of this, the HTK has three 1 1/8 " conduit mounting holes in the back of the cabinet, as well as six 1 1/8" conduit holes in the bottom of the cabinet.

**NOTE: When running your conduit refer to "HTK Bolt Pattern Brick-In" located on page 7.**

- Conduit carrying high voltage 120VAC power lines, should be connected to either one of the bottom 2 right or 1 back right conduit holes, as viewed from the front of the machine. These conduits are designated only for 110v for the power supply.
- Conduit carrying lines with 24VAC, 24VDC, 12VAC or 12VDC signals should be connected to either one of the four bottom left or back 2 left conduit holes, as viewed from the front of the machine.
- If any external communication lines (Cat 5 or Cat 5E, Video, POS etc.) are used, they should be run through separate conduit and connected to any of the open conduits on the left bottom or left back of the machine.

**NOTE: In the Free Standing cabinet there will be no conduit holes in the back.**

# HTK Dimensions (For brick-in installation)

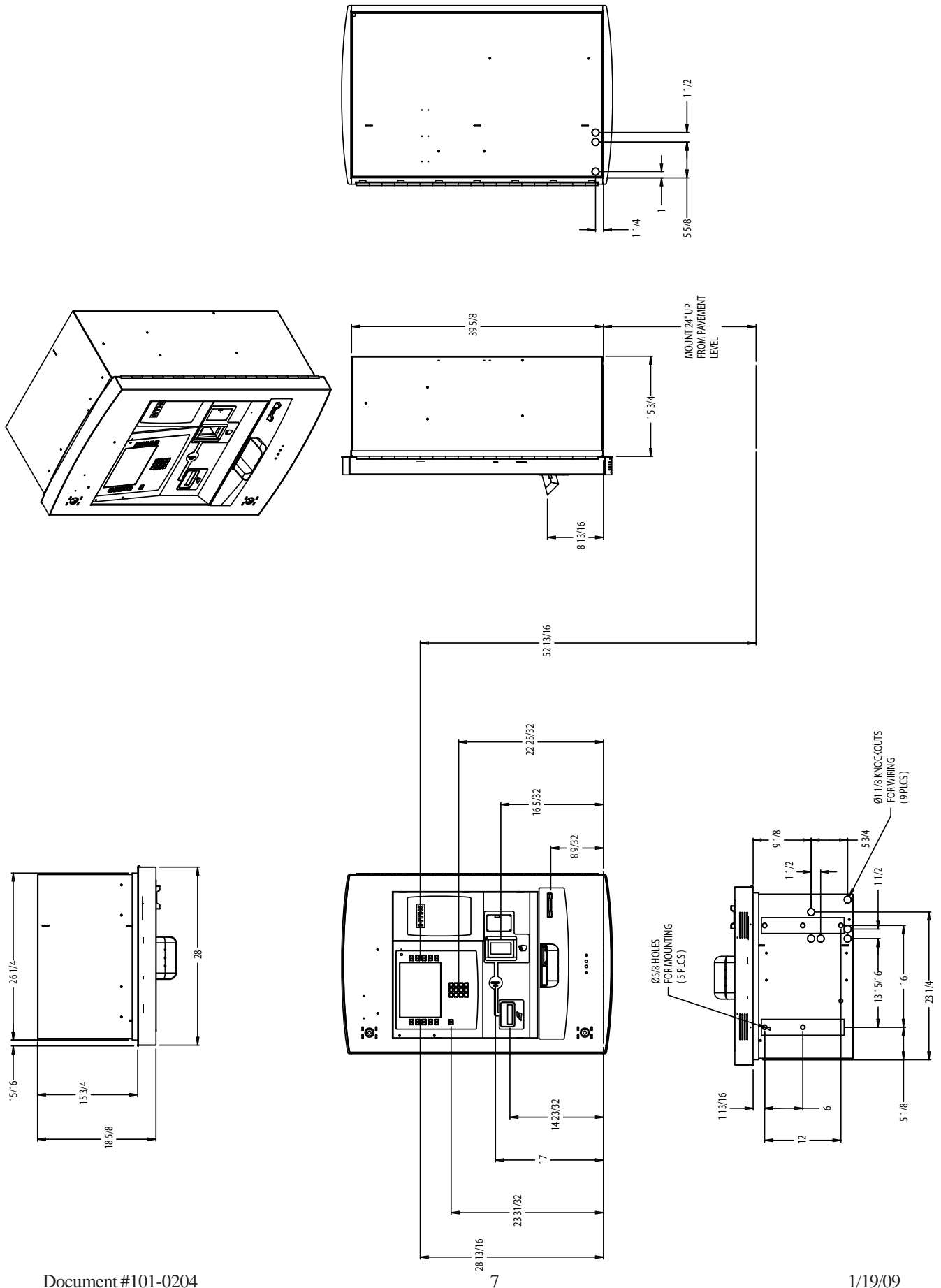

# HTK Dimensions (Free Standing installation)

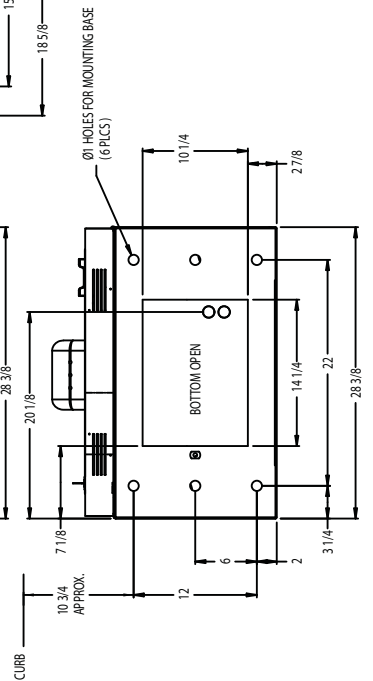
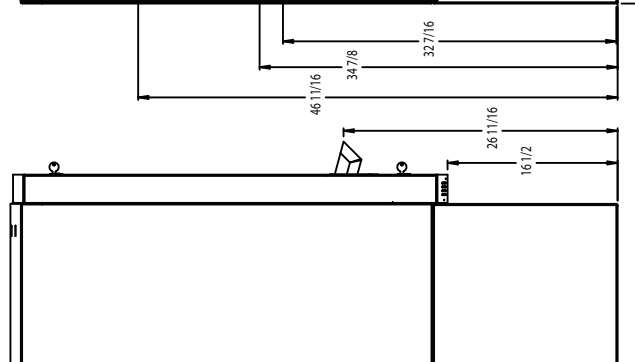
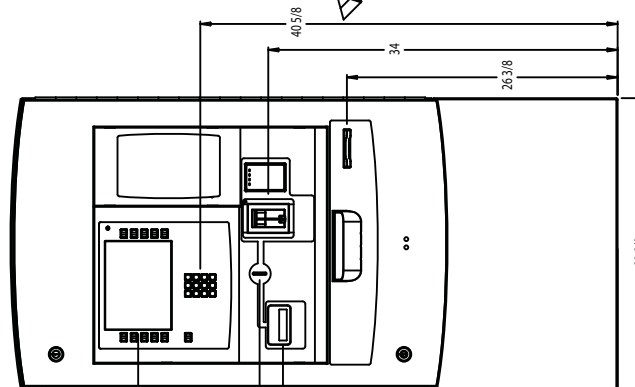
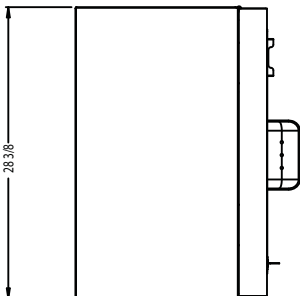
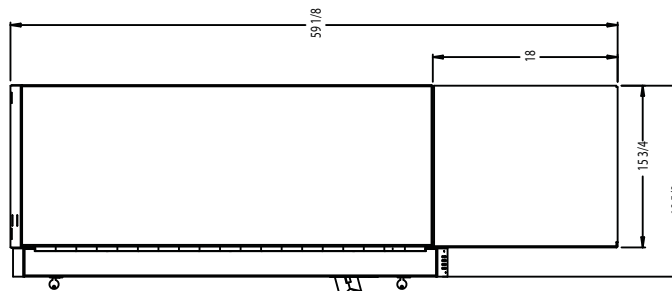
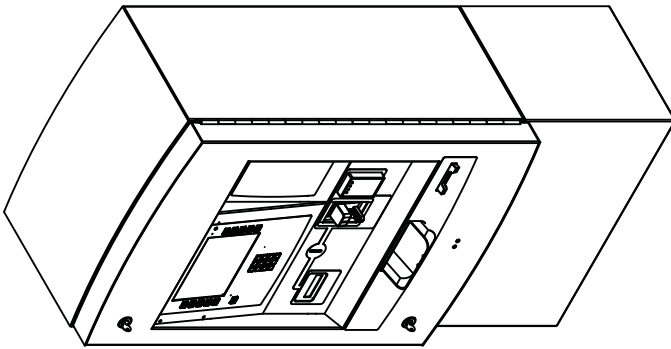



# Brick-In Installation

## HTK Bolt Pattern Brick-In

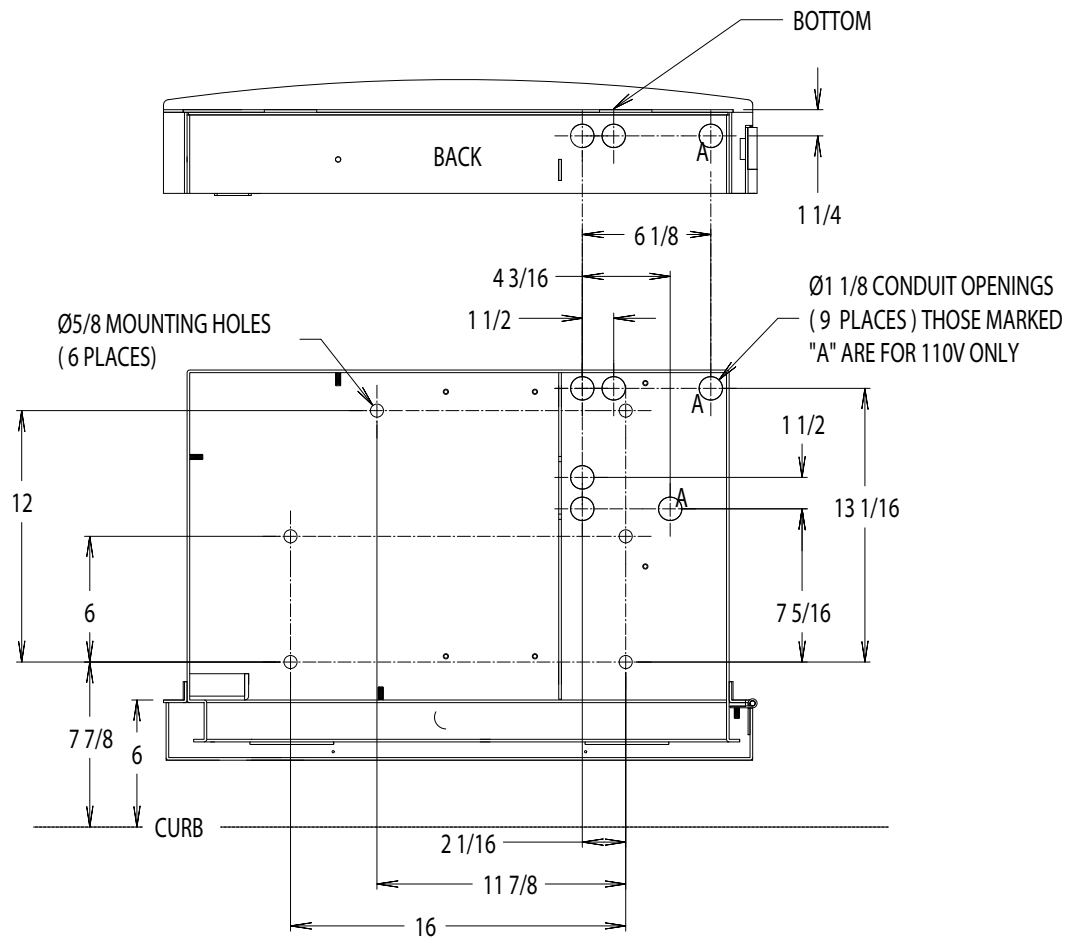

### Notes:

- 1- All foundations must be level and flat.
- 2- Verification of site specific conditions and Compliance with Federal, State, and Local Building Codes is the exclusive responsibility of the customer and /or architect and engineer.

# Free-Standing Installation

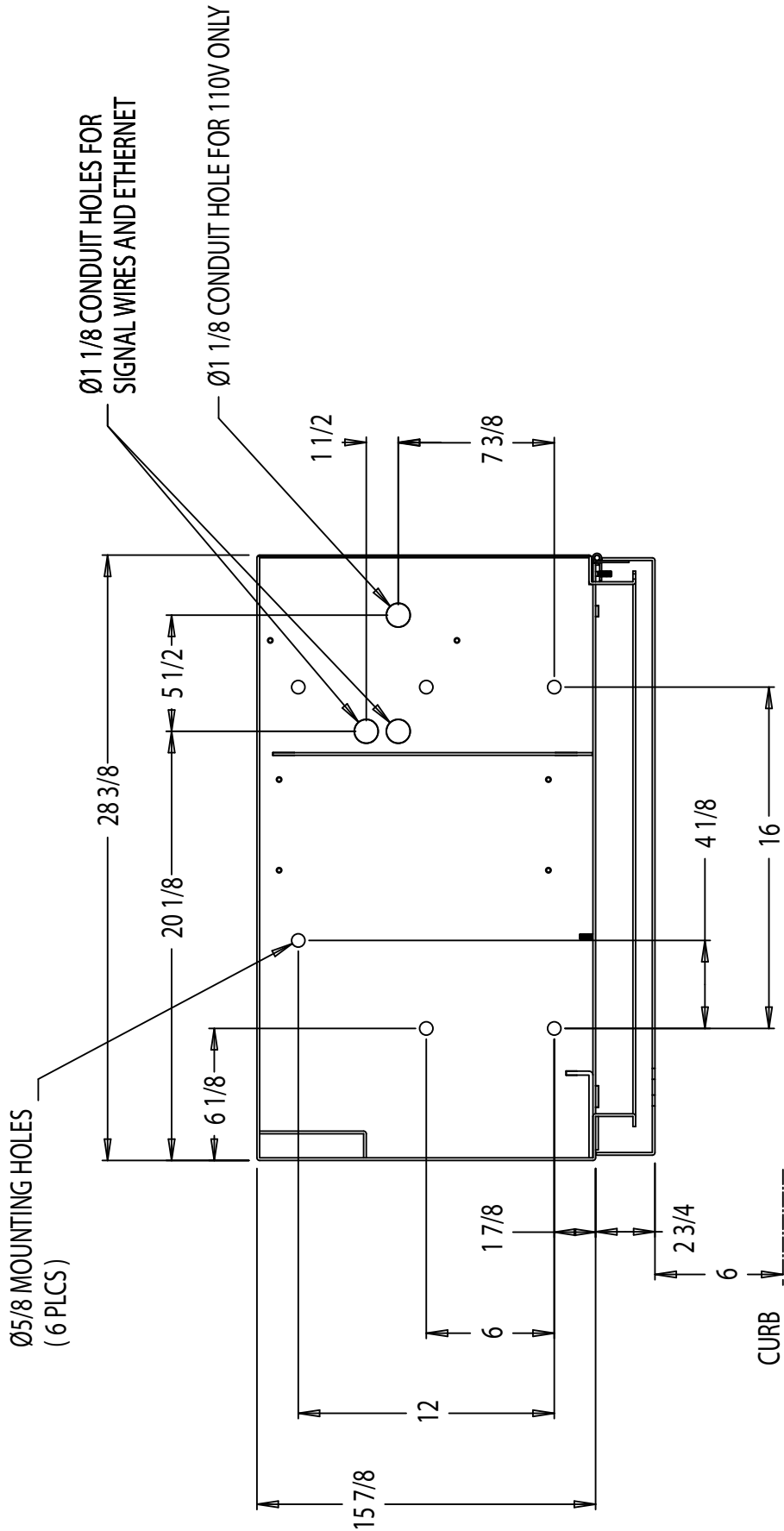

HTK FREE STANDING CABINET BOLT PATTERN  
(CUTAWAY VIEW OF BOTTOM OF CABINET)

# Brick-In Installation

## Brick-In HTK & Gate Configuration

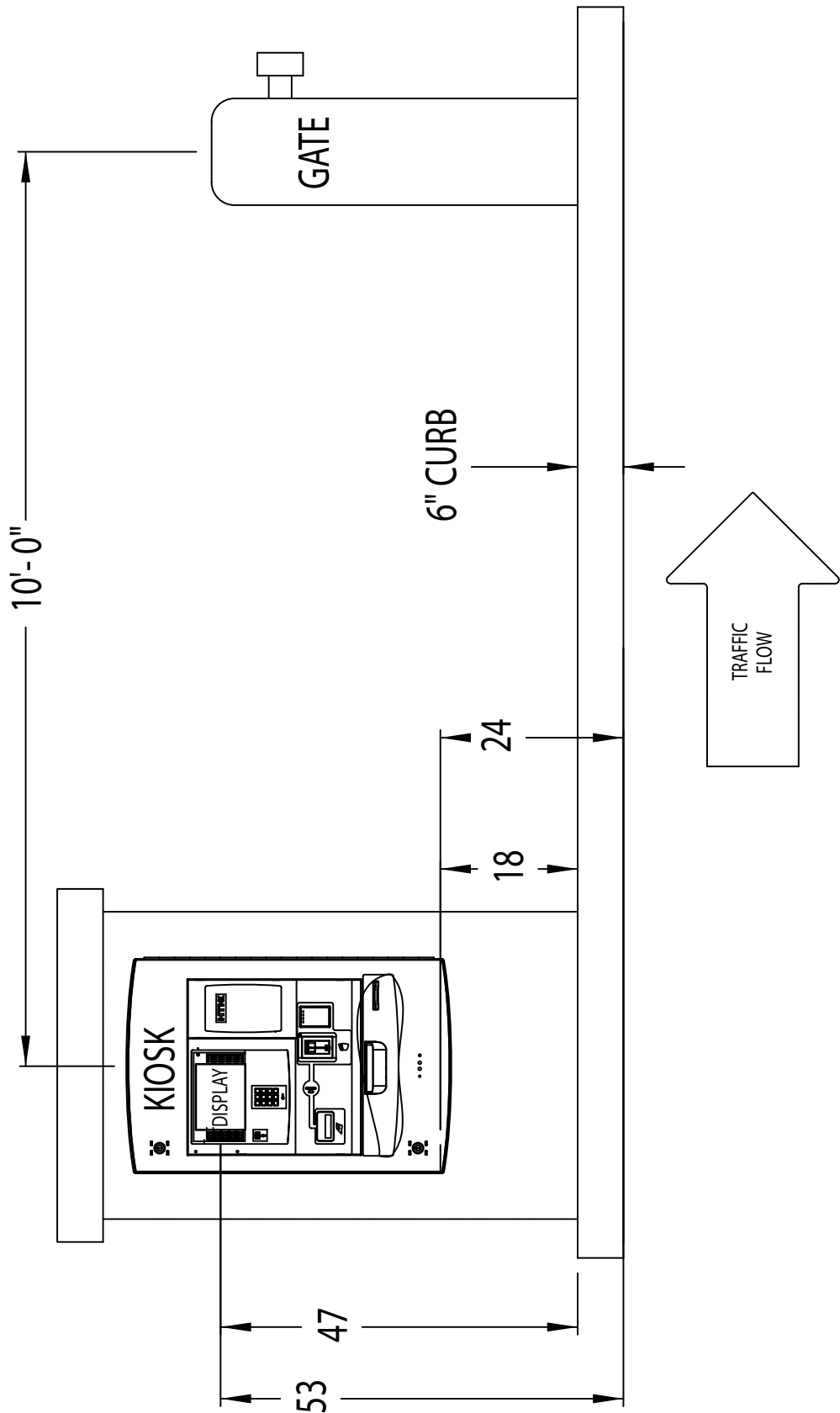

# Free-Standing Installation

## FREE STANDING HTK & Gate Configuration

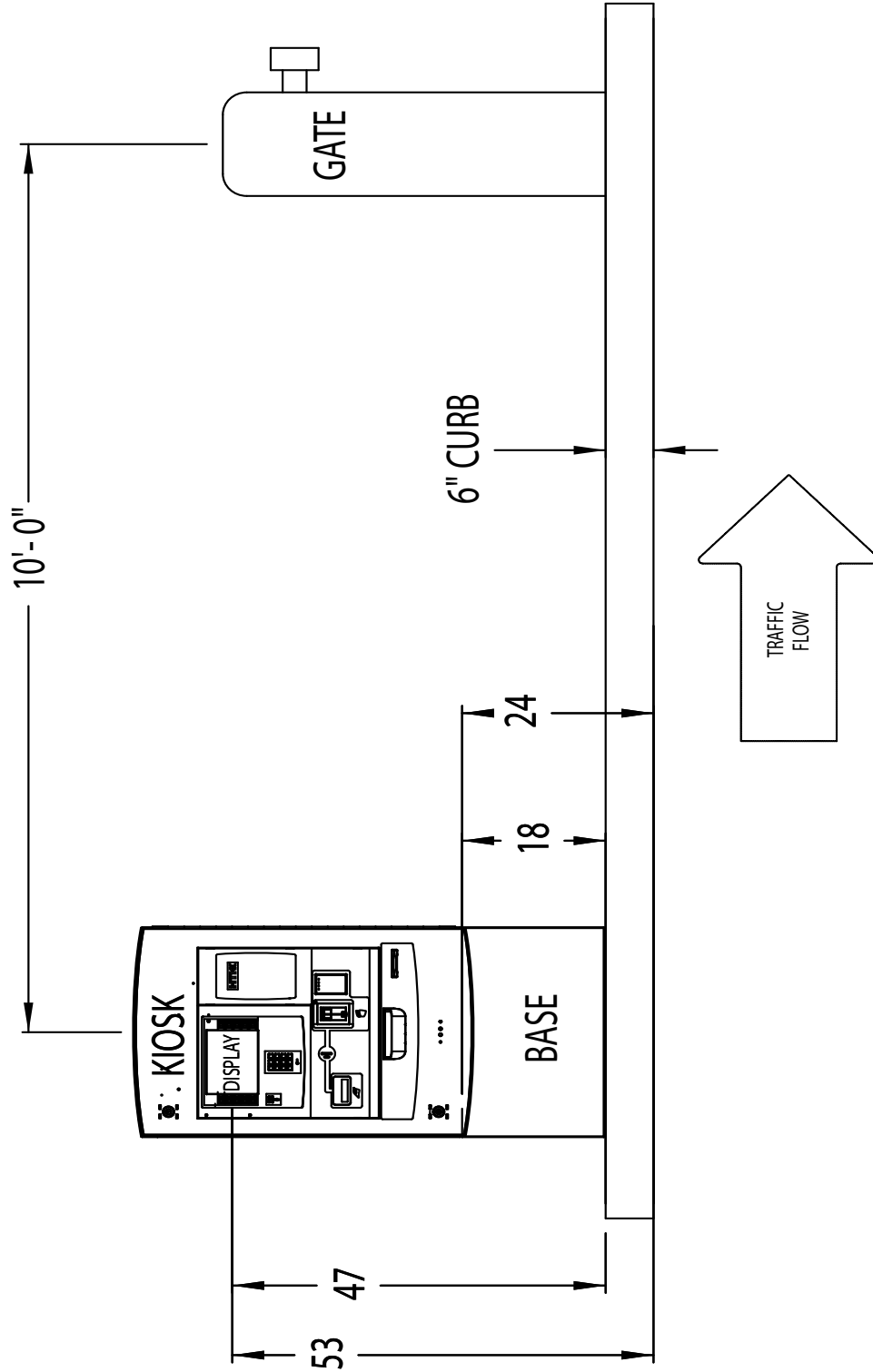

# Gate Orientation

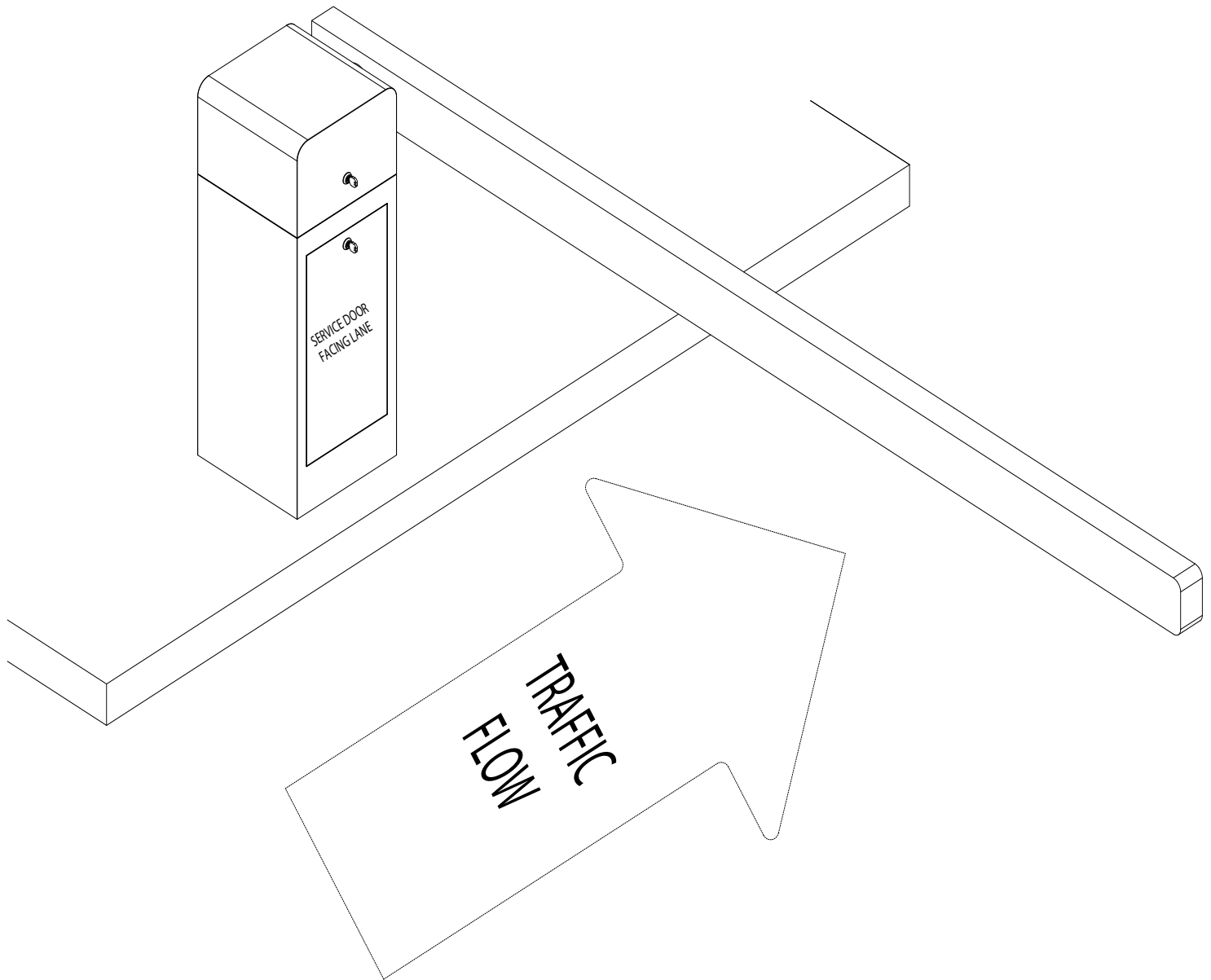

**CAUTION: WHEN MOUNTING THE GATE, THE SERVICE DOOR SHOULD BE FACING INTO THE LANE IF NOT MOUNTED CORRECTLY THE ARM WILL CLOSE IN THE WRONG DIRECTION. WHEN CORRECTED THE LOOP WILL NOT BE IN THE PROPER POSITION**

# Access Control Lane Layout

## Access Control Lane Layout

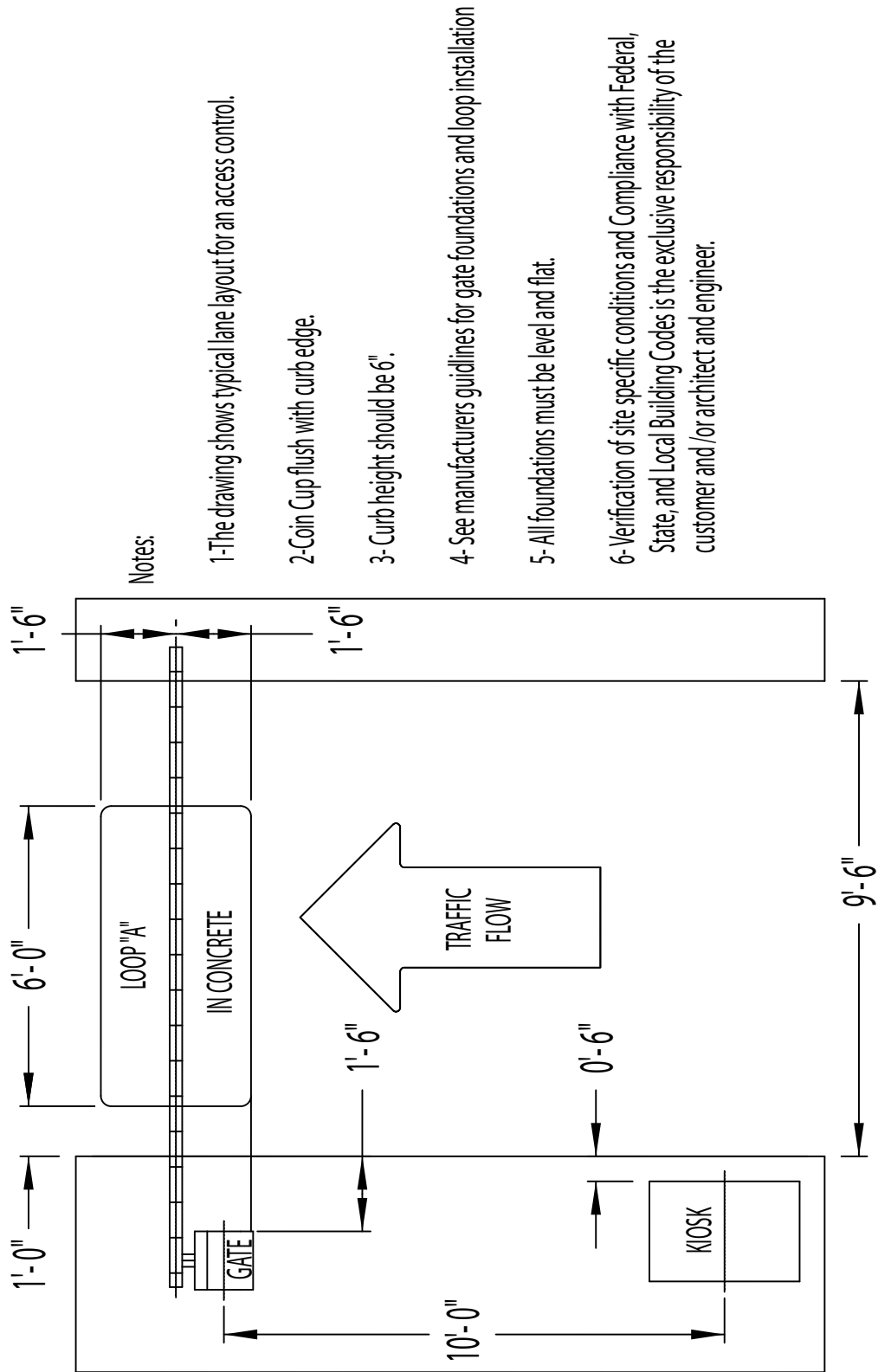

### Notes:

- 1-The drawing shows typical lane layout for an access control.
- 2-Coin Cup flush with curb edge.
- 3-Curb height should be 6".
- 4-See manufacturers guidelines for gate foundations and loop installation
- 5-All foundations must be level and flat.
- 6-Verification of site specific conditions and Compliance with Federal, State, and Local Building Codes is the exclusive responsibility of the customer and /or architect and engineer.

# III. Electrical Installation

---

---

**CAUTION! TO AVOID SEVER INJURY OR DEATH, ALWAYS DISCONNECT POWER TO THE MACHINE WHEN SERVICING!**

This HTK operates on 120 VAC, 60 Hz. This unit uses a 5 AMP Circuit Breaker. This unit needs to be hard-wired with conduit.

**\*IMPORTANT NOTICE: HAMILTON MFG. RECOMMENDS THAT THE HTK OPERATE ON A DEDICATED POWER SOURCE. UNDER NO CIRCUMSTANCE SHOULD ADDITIONAL EQUIPMENT BE OPERATING OFF THE DEDICATED POWER SOURCE FOR THE HTK.**

## □ Pulling Wires

The number of wires needed to be pulled for the HTK system is shown below:

Three Wires	Electrical Power (Hot, Neutral and Ground)
Five Wires	4 for Washes, 1 common
Two Wires	Cycle Inhibit
Spare Wires	For Future Options
2 Conductor Twisted Shielded Cable	Hamilton Code System/POS 4000
Cat 5	Credit Card & CVC Acceptance
Shielded Video Cable	Video

For proper operation of the HTK, all wires listed above must be pulled and terminated as explained in the following section.

## □ Wire Terminations

The wire terminations should proceed as follows:

- One side of the three power supply wires (120VAC HOT, 120VAC NEU, and 120VAC GND) should be attached directly to the electrical service panel supplying power to the installation. They should be connected to a 15 AMP circuit breaker and the HTK should be the only device on this circuit. The other end of these three wires should be routed into the HTK through the installed conduit. . The wires should be terminated as follows: Refer to “Power Supply” diagram on page 13.

**NOTE: The removal of the Power Supply and duplex outlet is recommended for ease of connection to backside of duplex outlet**

**NOTE: The signal presented to the car wash controller is a normally open, dry contact relay closure.**

**NOTE: For proper Vend connection refer to “Wash Interface” diagram page 14**

- The Vend 1 wire is used to signal the car wash controller that a customer has completed a transaction and has selected the Vend 1 sequence. The connection for Vend 1 is position 1 on the phoenix connector.
- The Vend 2 wire is used to signal the car wash controller that a customer has completed a transaction and has selected the Vend 2 sequence. The connection for Vend is position 2 on the phoenix connector.
- The Vend 3 wire is used to signal the car wash controller that a customer has completed a transaction and has selected the Vend 3 sequence. The connection for Vend 3 is position 3 on the phoenix connector.
- The Vend 4 wire is used to signal the car wash controller that a customer has completed a transaction and has selected the Vend 4 sequence. The connection for Vend 4 is position 4 on the phoenix connector.
- The Common wire pulled to the HTK from the car wash controller and is connected in Position 11 (C) of the phoenix connector on the Wash Interface.
- The CYCLE/INHIBIT wires are used for the car wash controller to signal the HTK when a car has completed its wash and left the bay. The signal coming from the car wash controller must be able to energize the coil of a relay on the wash interface. This means that the car wash controller must be supplying both voltage and current when it energizes the coil. Inside the HTK, the wiring connection depend on the signal provided by the car wash controller. The CYCLE/INHIBIT wires should be connected directly to the 4 position phoenix connector. Position 1 and 2 on the wash interface. Note: Refer to the “Wash Interface” for proper wiring connection.
- The OUT-OF SERVICE relay is included in the HTK. The connection is made at a 3 position phoenix connector on the controller. Position 1 (common), Position 2 (Normally closed) and Position 3 (normally open) Refer to “Controller” diagram on page 22.
- The ALARM relay is included in the HTK. The connection is made at a 3 position phoenix connector on the controller. Position 1 (common), Position 2 (normally closed) and Position 3 (normally open). Refer to “Controller” Diagram on page 22.

**NOTE: When setting up an HTK with the Hamilton Gated PLC and Gates please refer to diagram “HTK Gated Tunnel Diagram” for additional terminations needed at the Gated PLC and Gates. Refer to page 16.**



# Power Supply Wiring Connection

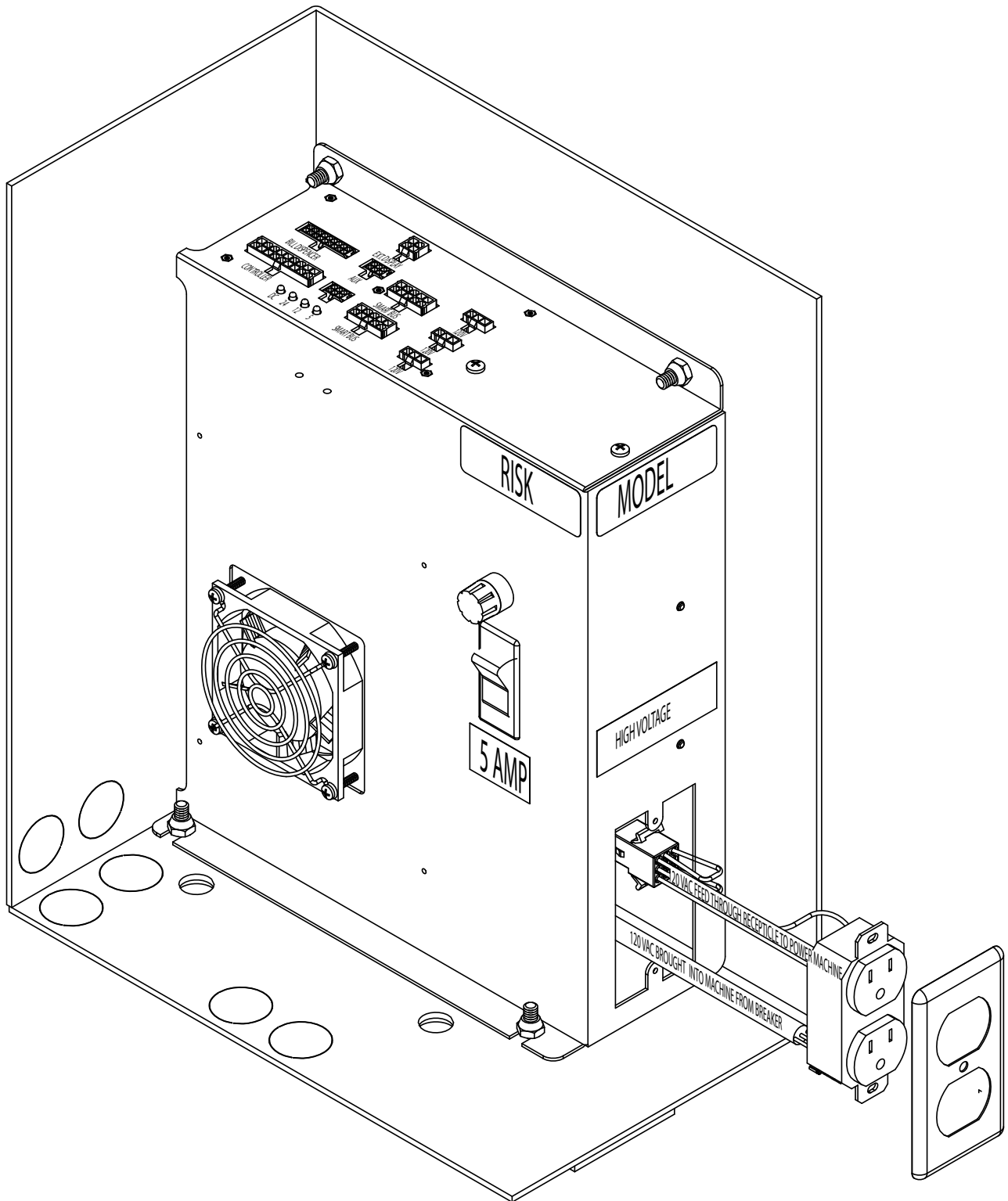

BRING MAIN POWER INTO OUTLET TO POWER MACHINE

# Wash Interface

## VEND OUTPUTS

- 1 = VEND 1
- 2 = VEND 2
- 3 = VEND 3
- 4 = VEND 4
- 5 = VEND 5
- 6 = VEND 6
- 7 = VEND 7
- 8 = VEND 8
- 9 = ISOLATED VEND
- 10 = ISOLATED VEND
- C = VEND COMMON

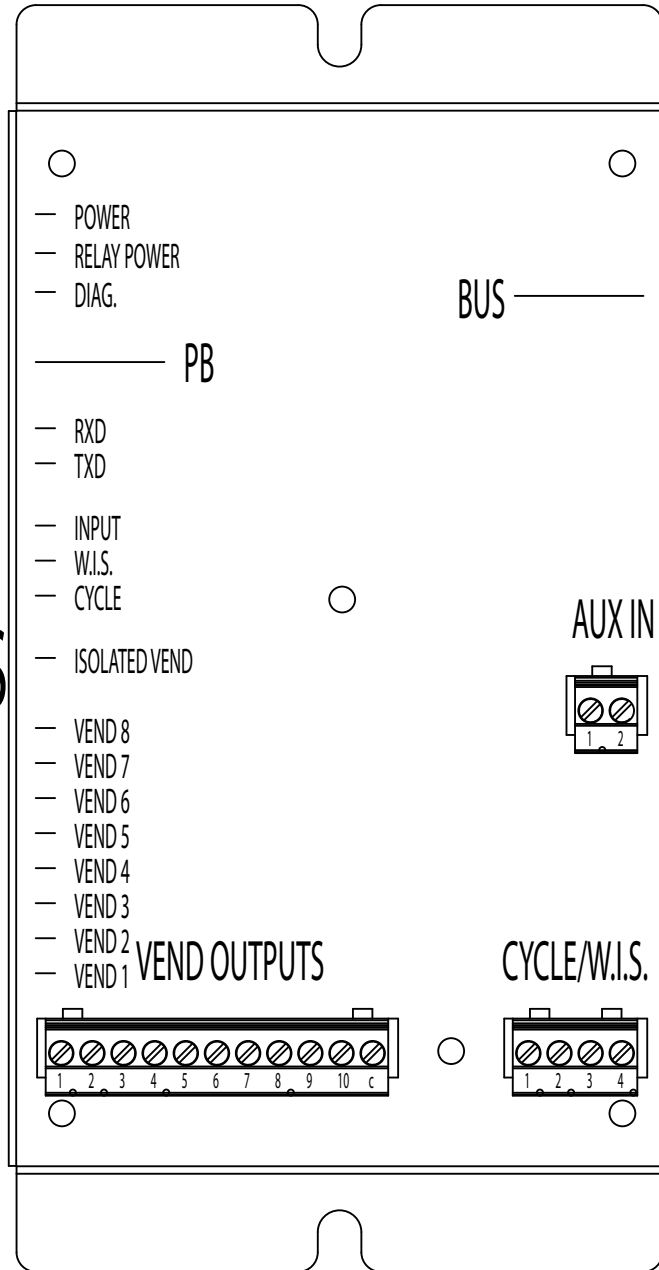

## AUX IN

1 & 2 NOT CURRENTLY USED

## CYCLE/W.I.S.

1 & 2 = CYCLE SIGNAL

3 & 4 = WASH IN SERVICE SIGNAL

# HTK "Automatic" Wiring

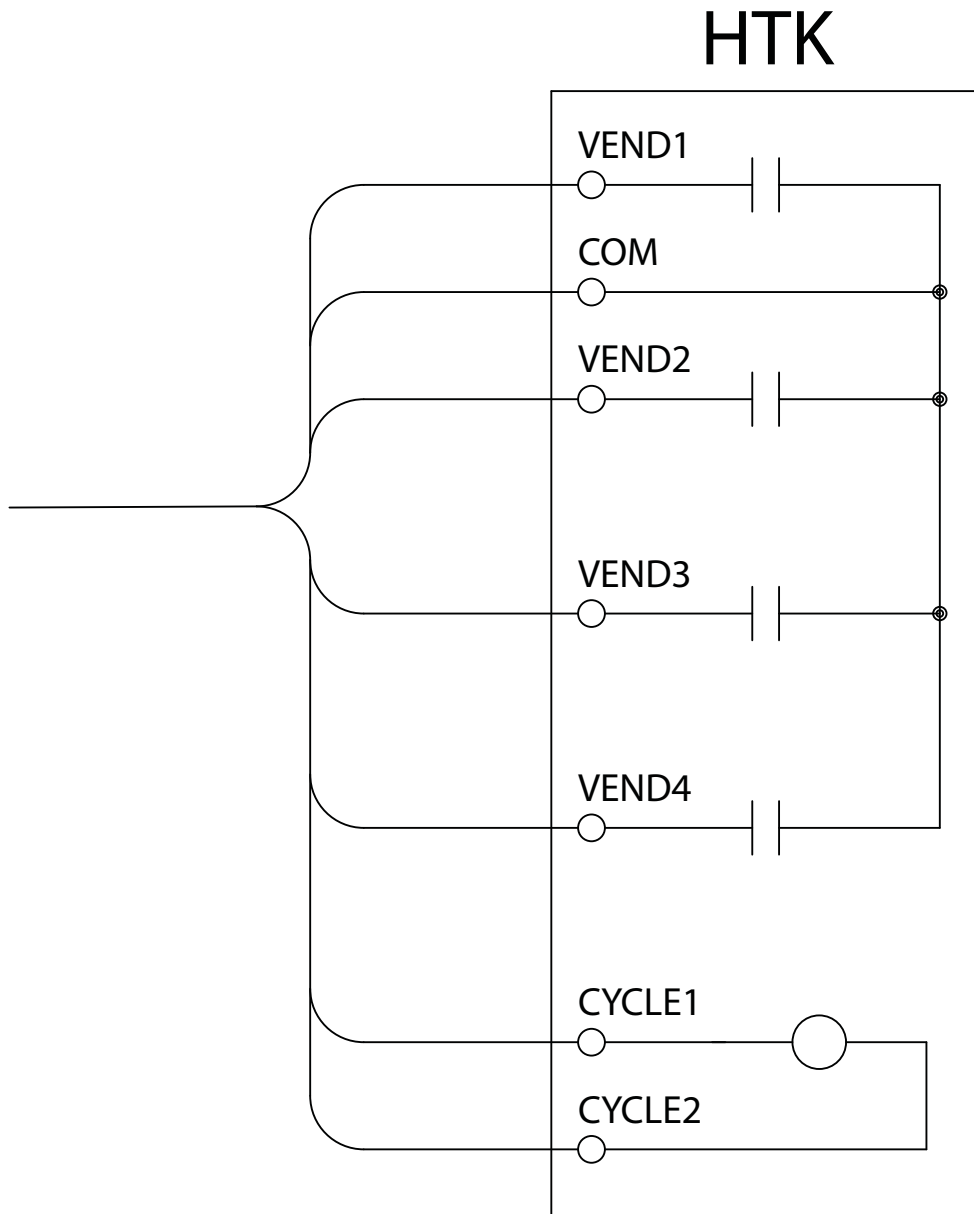

# HTK "Gated Tunnel" Wiring

HTK INTERCONNECTION DIAGRAM

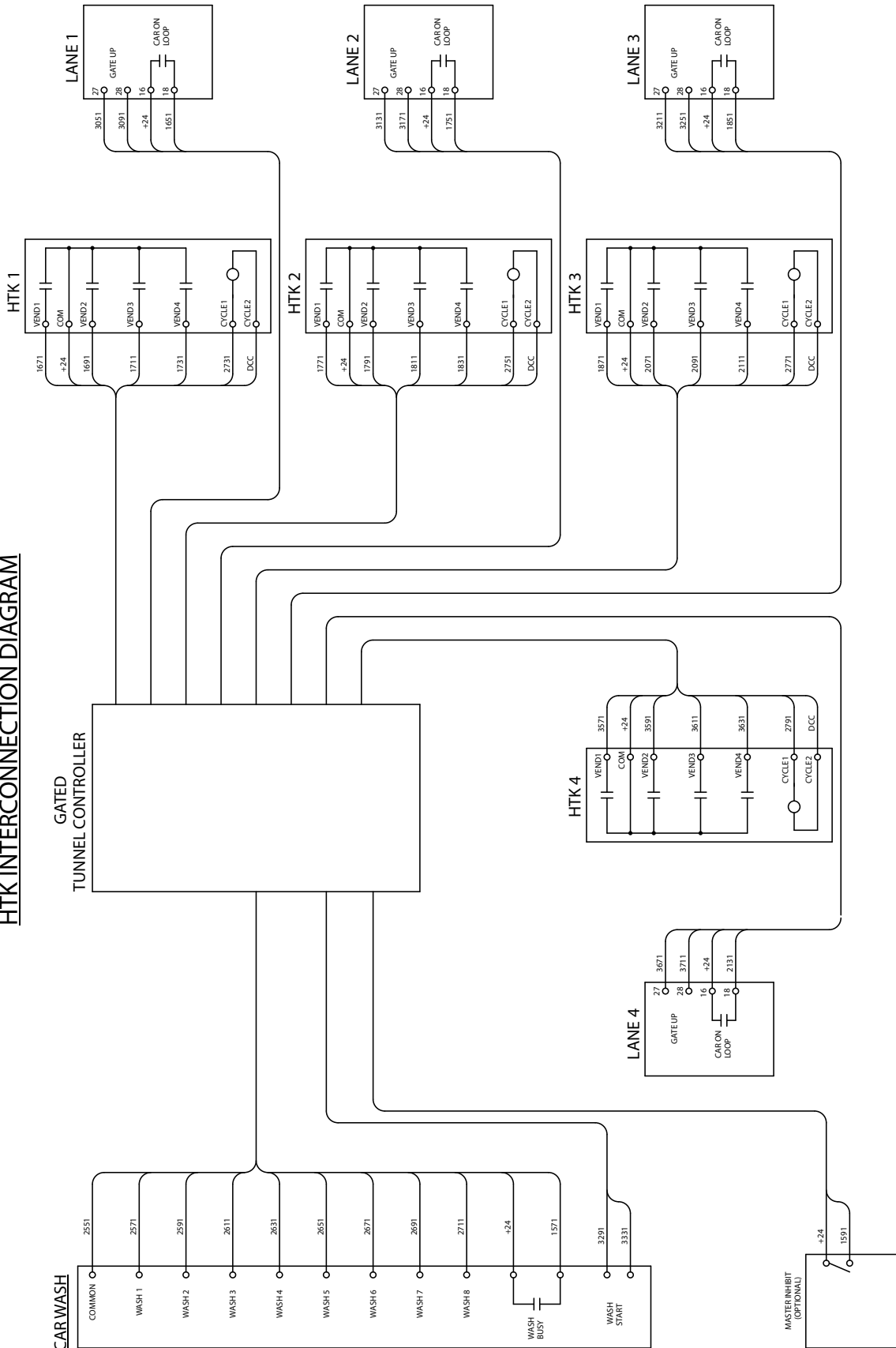

❑ Additional Wire Terminations For Use With The Credit Card or Customer Value Card System.

The installation of the machine should proceed as outlined in the above section. However, if a Credit Card or Customer Value Card System is being used, the following must be performed, as well.

- A Cat 5 or 5E cable should be pulled to each HTK on the site. The cable should be run from where the connection to the internet device (router or switch) is located back to the HTK. When crimping Cat 5 or 5E cable consult an electrician or network person for proper attachment.

**NOTE: When running Cat 5 or 5E cable, the run should be with out any splicing or mid point connections. If there are this can lead to communication issues.**

- The Cat 5 or 5E cable can be run in with the low voltage wires coming from the car wash.

❑ Additional Wire Terminations For Use With A Hamilton Code System or POS 4000

The installation of the machine should proceed as outlined in the above section. However, if a Hamilton Code System or POS 4000 is being used, the following must be performed, as well.

- A 485 communication line (A. 1 pair, twisted, shielded cable) should be pulled to each HTK on the site. The cable should be run from where the connection to the code system device (isolator box) is located back to the HTK. The connection to the HTK is on a 2 position phoenix connector located on the bottom side of the controller. Position 1 is the positive and Position 2 is the negative.

**NOTE: When running a 485 communication line, the run should be made with out any splicing or mid point connections. If there are this can lead to communication issues.**

- The 485 communication can be run in with low voltage wires coming from the car wash.

## □ Additional Wire Terminations For Camera In HTK.

The installation of the machine should proceed as outlined in the above section. However, if a Camera System is being used, the following must be performed, as well.

- A Video cable (shielded coaxial cable) should be pulled to each HTK on the site. The cable should be run from where the connection to the camera system is located back to the HTK. When terminating the video cable consult an electrician or network person for proper attachment.

**NOTE: When running video cable, the run should be made with out any splicing or mid point connections. If there are this can lead to communication issues. Hamilton supplies on the HTK side a standard BNC connector for video.**

- The Video cable can be run in with the low voltage wires coming from the car wash.

## ❑ Setting Car Wash Cycle Synchronization

The Car Wash Cycle Synchronization is a programmable setting in the HTK controller. The proper setting of this category depends on the equipment used in your car wash system. If the car wash equipment normally leaves the **CYCLE/INHIBIT RELAY** de-energized while in standby, and then energizes the relay when the customer enters the bay, the programming category should be set to **PASSIVE**. If the reverse occurs, where the car wash equipment normally energizes the **CYCLE/INHIBIT RELAY** while in standby, then de-energizes the relay when the customer enters the bay, the programming category should be set to **ACTIVE**.

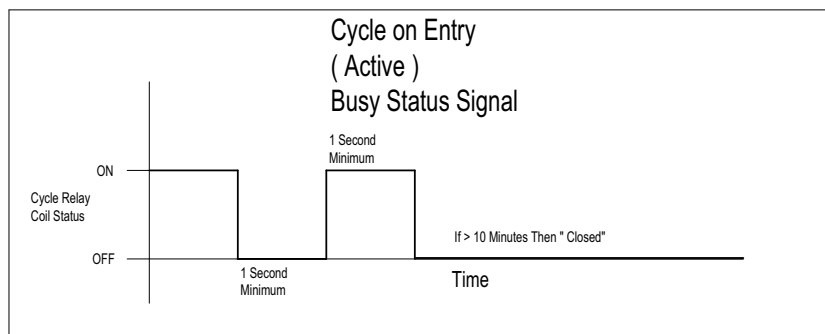
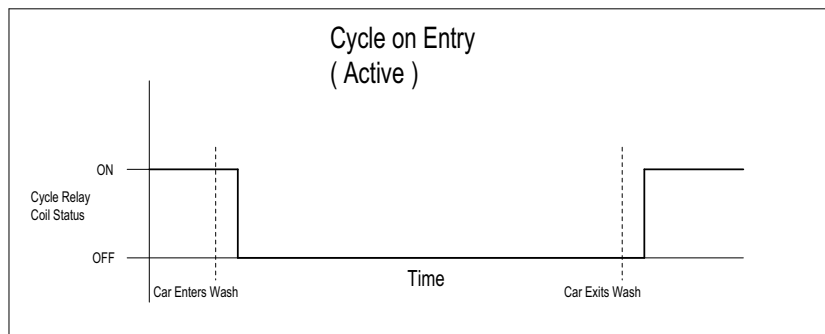
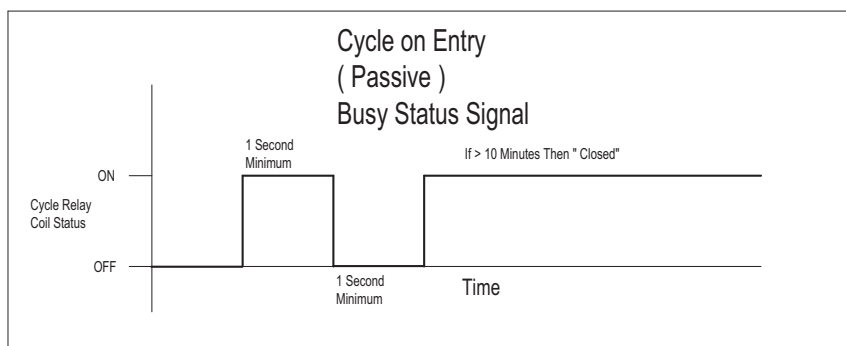
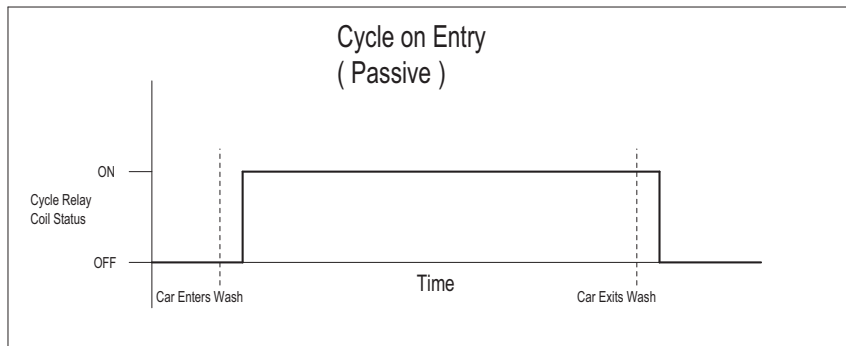

# IV. Component Connections

This section will provide schematics of the harness connections to the components inside the HTK cabinet. This will include the Power Supply (page 21), Controller (page 22), Smart Bus Hub (page 24), Bill Dispenser (page 25), and Stacker Interface (page 26).



# Power Supply

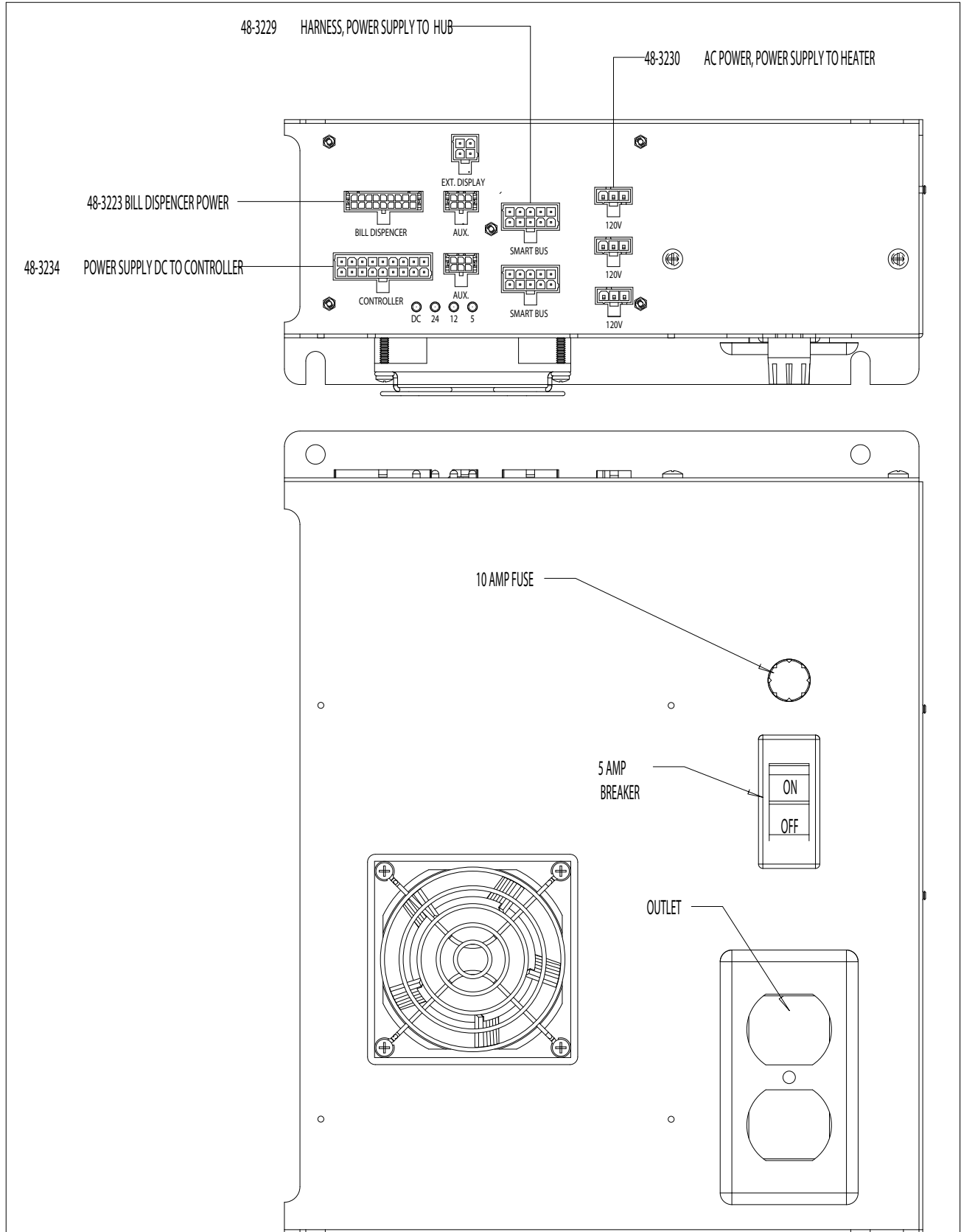

# Controller

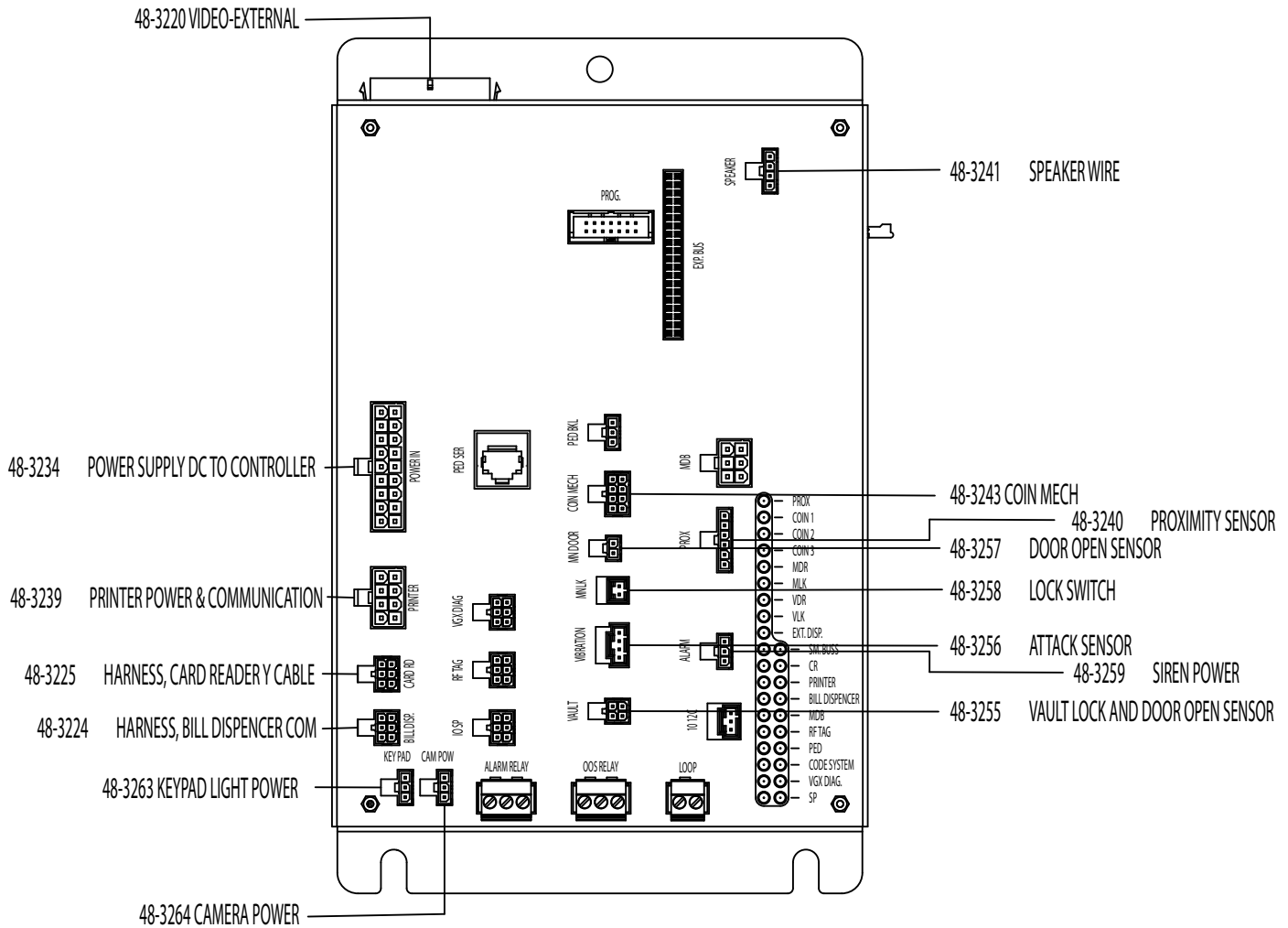

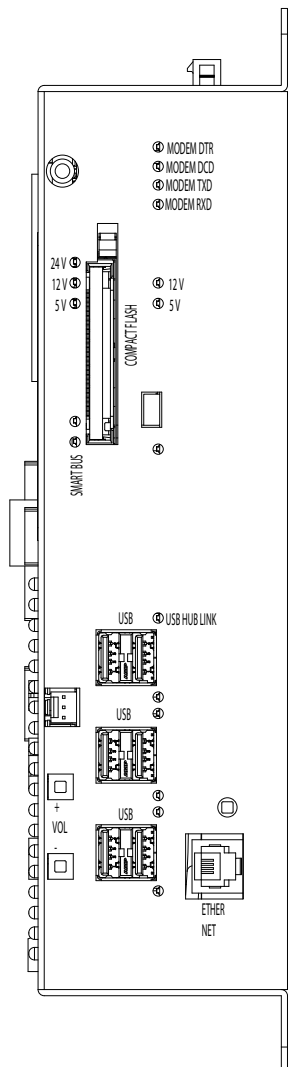

RIGHT SIDE VIEW

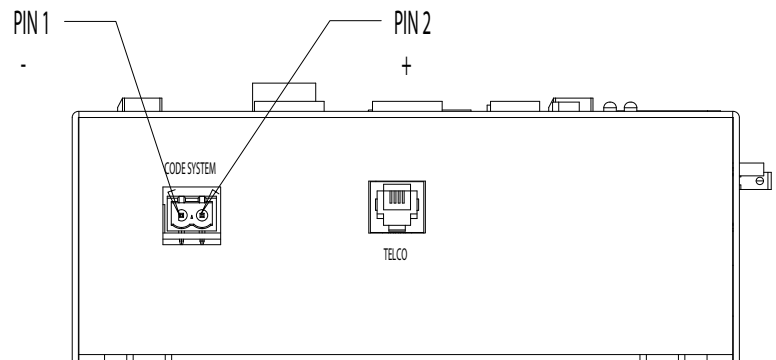

BOTTOM VIEW

# Smart Bus Hub

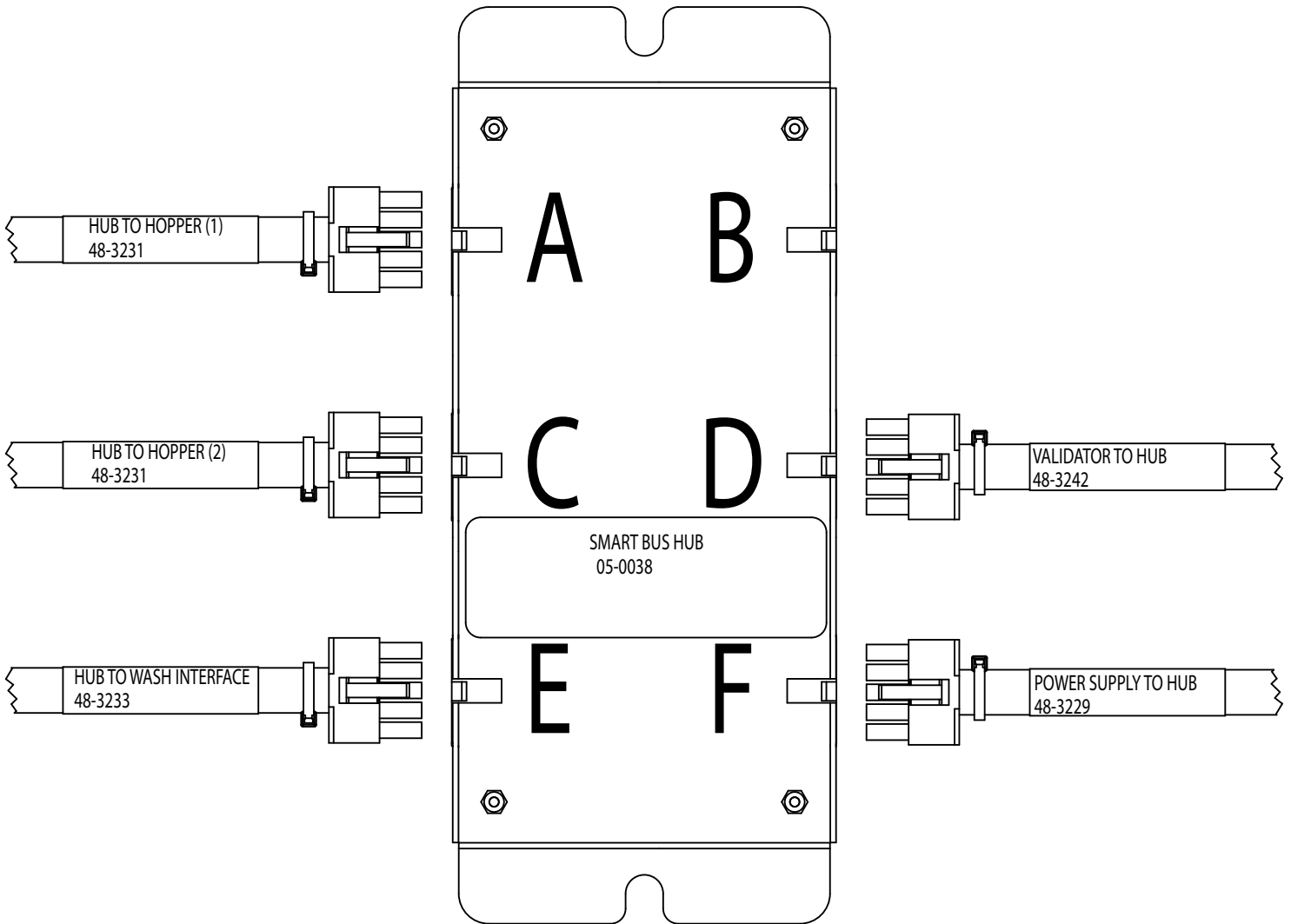

# Bill Dispenser

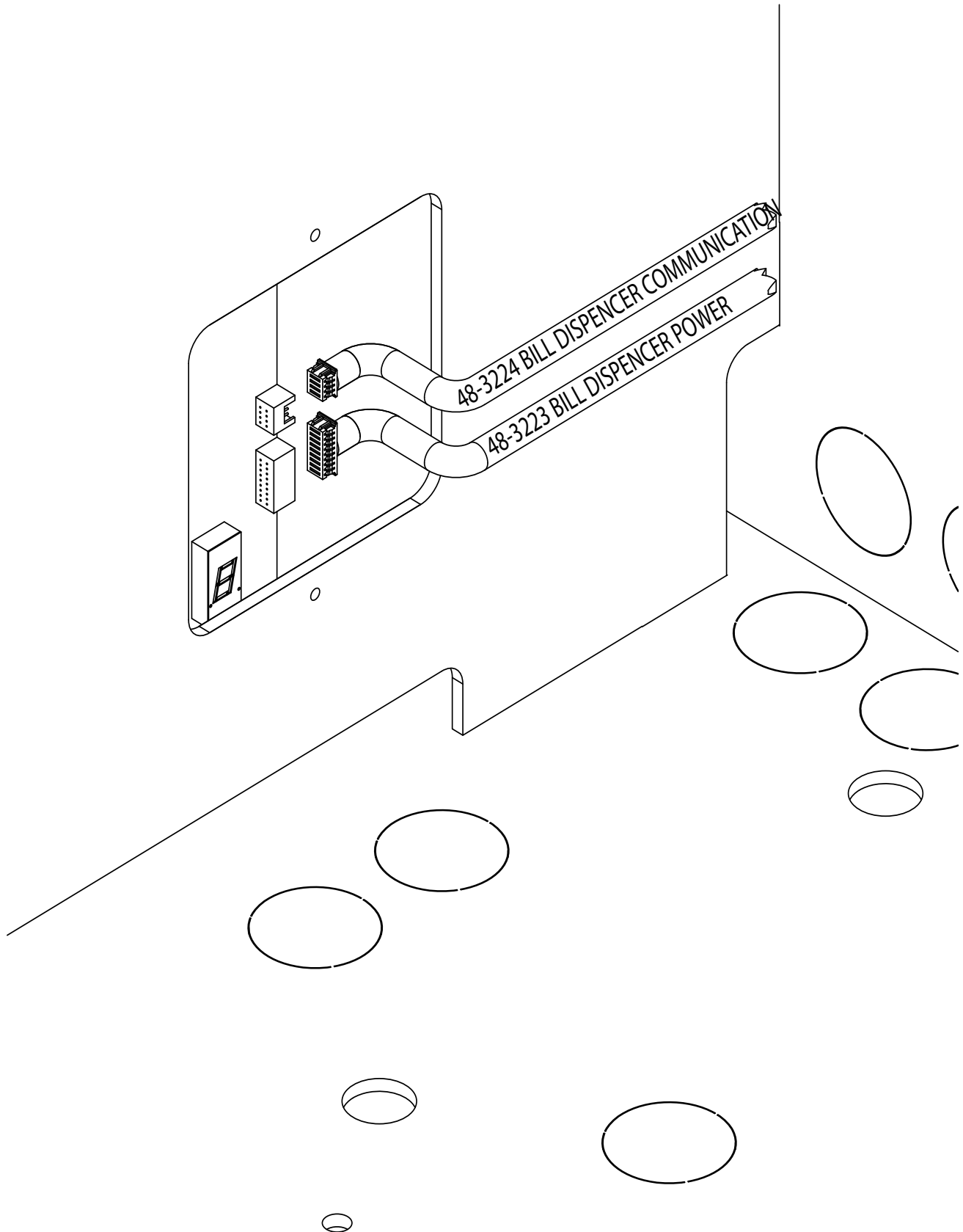

# Stacker Interface

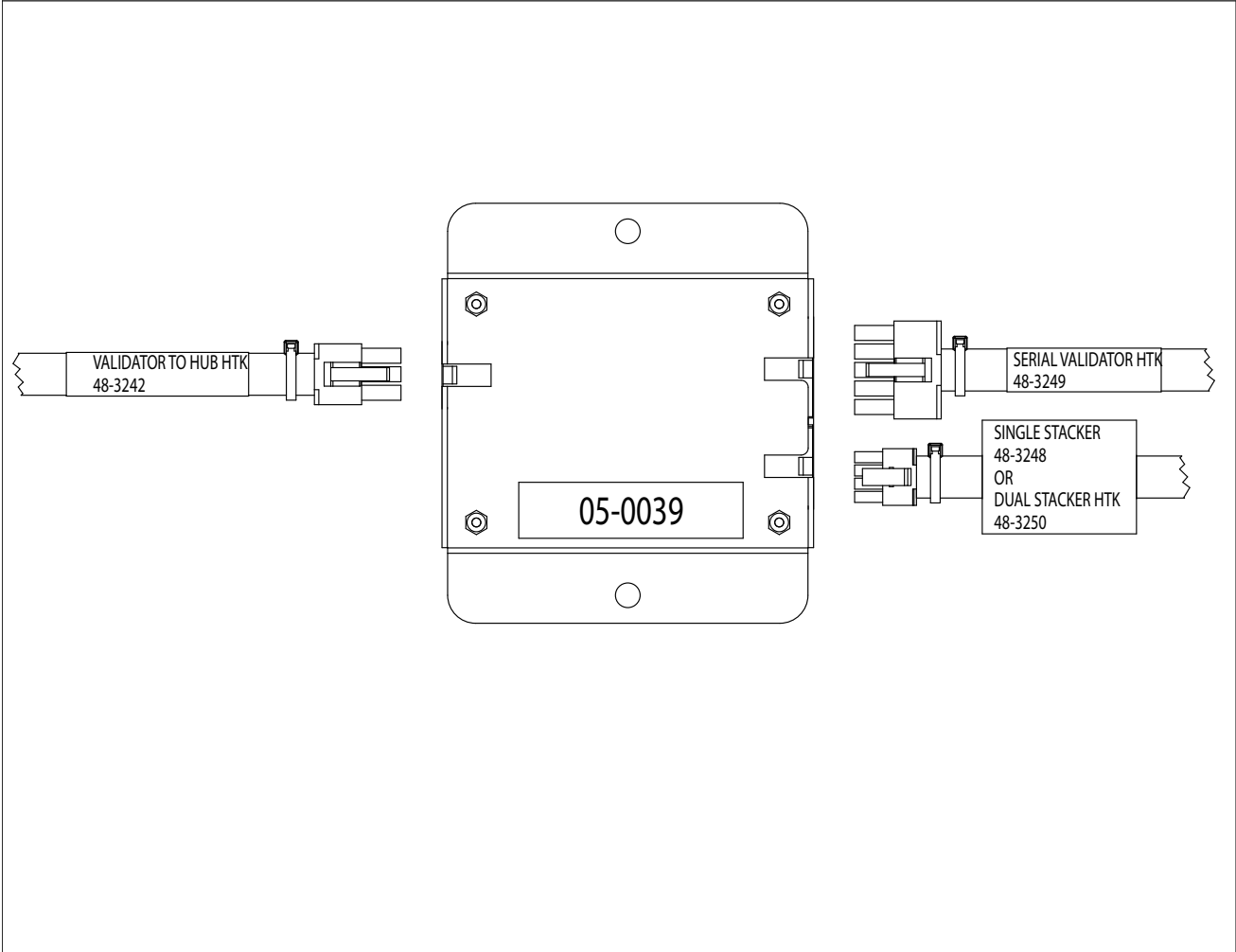

# Gate and Loop References

Website for Gates and Loop Installation Instructions  
Magnetic Autocontrol

<http://www.ac-magnetic.com/start/3-En.html> (Website)

[http://www.ac-magnetic.com/pdf/manuals/41-En-Mf\\_5115\\_Magstop\\_US.pdf](http://www.ac-magnetic.com/pdf/manuals/41-En-Mf_5115_Magstop_US.pdf) (Foundation)

[http://www.ac-magnetic.com/pdf/manuals/42-En-MF\\_5117\\_Magstop\\_US.pdf](http://www.ac-magnetic.com/pdf/manuals/42-En-MF_5117_Magstop_US.pdf) (Loop)

[http://www.ac.magnetic.com/pdf/manual/43-En-MIB30\\_40%20Operation%20MANUAL%202004\\_05.pdf](http://www.ac.magnetic.com/pdf/manual/43-En-MIB30_40%20Operation%20MANUAL%202004_05.pdf) (Manual)

## **LIMITED WARRANTY AGREEMENT OF HAMILTON MANUFACTURING CORP.**

Hamilton Manufacturing Corp., an Ohio Corporation, (“Seller”) warrants to Purchaser that all new equipment shall be free from defects in material and factory workmanship for a period of one (1) year from the original shipping date. Hamilton Manufacturing Corp. further warrants if any part of said new equipment in Seller’s sole opinion, requires replacement or repair due to a defect in material or factory workmanship during said period, Seller will repair or replace said new equipment. Purchaser’s remedies and the liabilities and obligations of Seller herein shall be limited to repair or replacement of the equipment as Seller may choose, and Seller’s obligation to remedy such defects shall not exceed the Purchaser’s original cost for the equipment. Purchaser EXPRESSLY AGREES this is the EXCLUSIVE REMEDY under this warranty. There are no other express or implied warranties which extend beyond the face hereof. All warranty repair service must be performed by either a Factory Trained Service Representative or **HAMILTON MANUFACTURING CORP., 1026 Hamilton Drive, Holland, Ohio 43528 PHONE (419) 867-4858 or (800) 837-5561, FAX (419) 867-4867.**

The limited warranty for new equipment is conditioned upon the following:

1. The subject equipment has not, in the Seller’s sole opinion, been subjected to: accident, abuse, misuse, vandalism, civil disobedience, riots, acts of God, natural disaster, acts of war or terrorism.
2. The Seller shall not be liable for any expense incurred by Purchaser incidental to the repair or replacement of equipment and Purchaser shall assume full responsibility for any freight or shipping charges.
3. The coverage of this warranty shall not extend to expendable parts.
4. Purchaser shall have a warranty registration card on file with Seller prior to any claim in order for warranty protection to apply.
5. No warranty coverage is applicable to any equipment used for currency other than that specified at the time of the purchase.
6. Seller expressly disclaims any warranty that counterfeit currency will not activate said equipment.
7. Seller expressly disclaims any warranty for any losses due to bill manipulation or theft or loss of cash under any circumstances.
8. Use of the equipment for anything other than its intended and designed use will void the Limited Warranty Agreement. Use of equipment for anything other than its intended and designed use includes, but is not limited to, downloading software/applications not certified by Seller such as e-mail, spyware, screen savers, viruses, worms, third party software, web search engines, cookies, spam, desktop applications, games, web surfing, etc.

Seller further warrants all repair or service work performed by a factory trained representative or Hamilton Manufacturing Corp. for a period of ninety (90) days from the date the repair or service work was performed. Purchaser’s remedies and the liabilities and obligations of Seller herein shall be limited to repair or replacement of equipment as Seller may choose, and Seller’s obligation to remedy such defects shall not exceed the Purchaser’s depreciated value of the equipment. Purchaser EXPRESSLY AGREES this is an EXCLUSIVE REMEDY under this warranty. There are no other express or implied warranties on repair or service work performed by a factory trained representative or Hamilton Manufacturing Corp. which extend beyond the face hereof.



The limited warranty for repair and service work is conditioned upon the following:

1. The subject equipment has not, in the Seller's sole opinion, been subjected to: accident, abuse, misuse, vandalism, civil disobedience, riots, acts of God, natural disaster, acts of war or terrorism.
2. The Seller shall not be liable for any expense incurred by Purchaser incidental to the repair or replacement of equipment and Purchaser shall assume full responsibility for any freight or shipping charges.
3. The coverage of this warranty shall not extend to expendable parts.
4. Purchaser shall have a warranty registration card on file with Seller prior to any claim in order for warranty protection to apply.
5. No warranty coverage is applicable to any equipment used for currency other than that specified at the time of the purchase.
6. Seller expressly disclaims any warranty that counterfeit currency will not activate said equipment.
7. Seller expressly disclaims any warranty for any losses due to bill manipulation or theft or loss of cash under any circumstances.
8. No person or entity other than a factory trained representative or Hamilton Manufacturing Corp. has performed or attempted to perform the subject repair or service.
9. Using equipment which has been serviced or repaired for anything other than its intended or designed use such as downloading software applications not certified by Seller will void the Limited Warranty Agreement. This includes software/applications such as e-mail, spyware, screen savers, viruses, worms, third party software, web search engines, cookies, spam, desktop applications, games, web surfing, etc.

THIS AGREEMENT IS MADE WITH THE EXPRESS UNDERSTANDING THAT THERE ARE NO IMPLIED WARRANTIES THAT THE EQUIPMENT SHALL BE MERCHANTABLE, OR THAT THE GOODS SHALL BE FIT FOR ANY PARTICULAR PURPOSE. PURCHASER HEREBY ACKNOWLEDGES THAT IT IS NOT RELYING ON THE SELLER'S SKILL OR JUDGMENT TO SELECT OR FURNISH EQUIPMENT SUITABLE FOR ANY PARTICULAR PURPOSE AND THAT THERE ARE NO WARRANTIES WHICH EXTEND BEYOND THAT WHICH IS DESCRIBED HEREIN.

The Purchaser agrees that in no event will the Seller be liable for direct, indirect, or consequential damages or for injury resulting from any defective or non-conforming new, repaired or serviced equipment, or for any loss, damage or expense of any kind, including loss of profits, business interruption, loss of business information or other pecuniary loss arising in connection with this Limited Warranty Agreement, or with the use of, or inability to use the subject equipment regardless of Sellers knowledge of the possibility of the same.

## **Hamilton Manufacturing Corp.**

1026 Hamilton Drive  
Holland, OH 43528

**Sales Phone:** (888) 723-4858    **Sales Fax:** (419) 867-4850  
**Customer Service Phone:** (800) 837-5561    **Customer Service Fax:** (419) 867-4857  
**Parts Phone:** (866) 835-1721    **Parts Fax:** (419) 867-4867

**Website:** <http://www.hamiltonmfg.com>

**Email Addresses:**

[service@hamiltonmfg.com](mailto:service@hamiltonmfg.com)

[sales@hamiltonmfg.com](mailto:sales@hamiltonmfg.com)

[parts@hamiltonmfg.com](mailto:parts@hamiltonmfg.com)